

A REV. WEAR PL. WELDS & ADDED SEAMLESS STEEL TO BUSHING
 B CHANGED KNUCKLE CAT. NO.

COLUMBUS STEEL CASTINGS RESERVES THE RIGHT TO MODIFY DETAILS NOT AFFECTING APPLICATION OR STRENGTH IF NECESSARY TO FACILITATE MANUFACTURE.

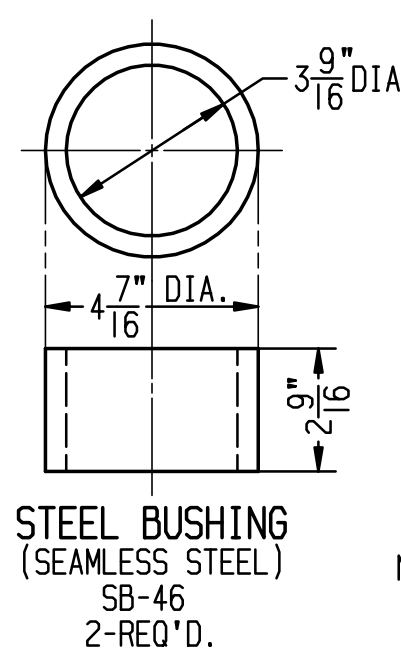
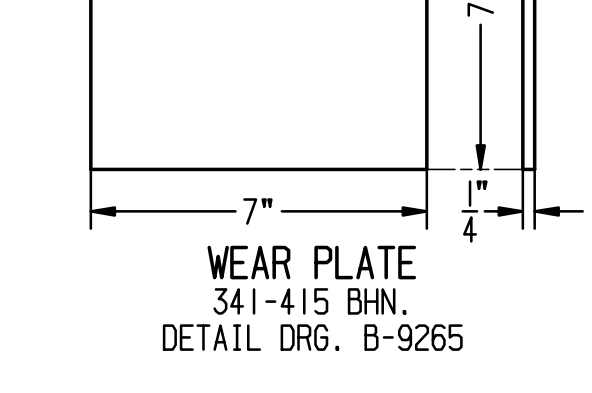
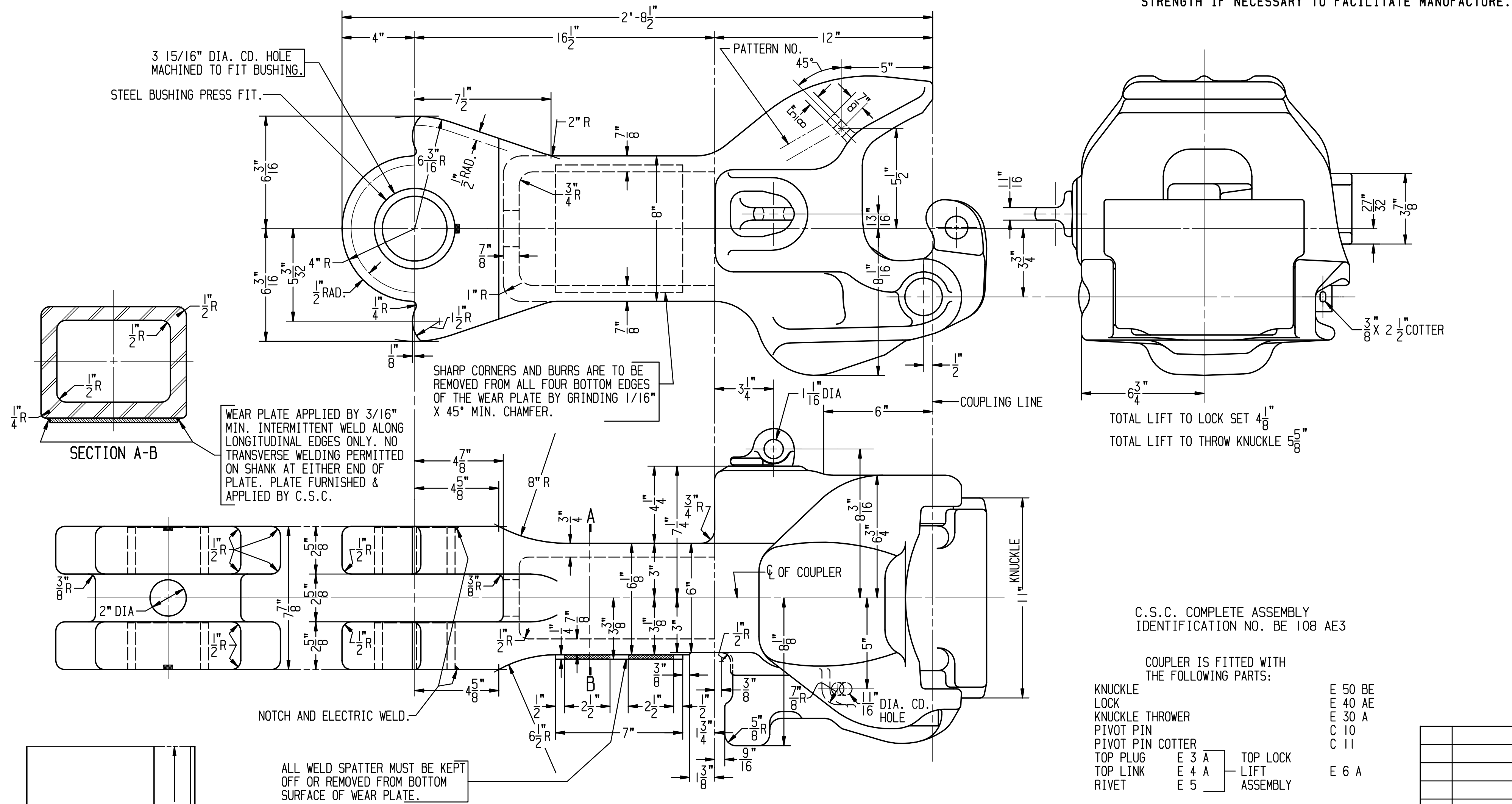

COUPLER BODY
 HIGH TENSILE STEEL GRADE "E" TO A.A.R. SPECIFICATION M-211, LATEST REVISION.
 PATTERN NO. BE-108-AE

NOTE:
 DIMENSIONS WHICH ARE NOT TOLERANCED ARE SUBJECT TO MANUFACTURING VARIATIONS.

REFERENCE ONLY

THIS DRAWING CONTAINS CONFIDENTIAL AND PROPRIETARY INFORMATION OF COLUMBUS STEEL CASTINGS ("COLUMBUS STEEL") AND THE DRAWING AND THE INFORMATION CONTAINED THEREIN ARE AND REMAIN THE PROPERTY OF COLUMBUS STEEL. THIS DRAWING IS PROVIDED WITH THE EXPRESS AGREEMENT THAT THE DRAWING AND THE INFORMATION THEREIN:
 (1) WILL NOT BE REPRODUCED, COPIED OR OTHERWISE TRANSCRIBED, IN WHOLE OR IN PART, BY ANY METHOD;
 (2) WILL NOT BE USED, IN WHOLE OR IN PART, DIRECTLY OR INDIRECTLY, TO ASSIST IN THE MAKING OR TO FURNISH ANY INFORMATION FOR THE MAKING, OF DRAWINGS, PRINTS, APPARATUS OR PARTS;
 (3) WILL NOT BE MADE AVAILABLE TO ANY OTHER PERSON OR ENTITY, IN EACH CASE WITHOUT THE PRIOR WRITTEN CONSENT OF COLUMBUS STEEL AS TO EACH SPECIFIC CASE; AND
 (4) WILL BE RETURNED TO COLUMBUS STEEL UPON ITS REQUEST.
 ACCEPTANCE OF THIS DRAWING SHALL CONSTITUTE ACCEPTANCE OF THE FOREGOING AGREEMENTS.

TYPE "E" COUPLER
 TOP OPERATING
 PATTERN NO. BE-108-AE

Columbus Steel Castings
 Columbus, Ohio

DRAWN BY T.A.P./D.C.M.	CHECKED BY G.L.C./K.A.C.	DATE 4-16-1993
C-14055		SCALE 3" = 1'-0"
		SHEET 1 OF 1