

A REDUCED SLACK TAIL WALL PAD ADDED. CHANGED KNUCKLE AND LOCK CATALOG NO.'S. & COUPLER IDENTIFICATION NO.
 B CHANGED B.S.C. COMPLETE ASS'Y. I.D. NO.
 C ADDED LOCK WALL TO TAIL WALL PAD DIM. AND NOTE, CHG'D. B.S.C. CO. COMPLETE ASS'Y. I.D. NO.

COLUMBUS STEEL CASTINGS RESERVES THE RIGHT TO MODIFY DETAILS NOT AFFECTING APPLICATION OR STRENGTH IF NECESSARY TO FACILITATE MANUFACTURE.

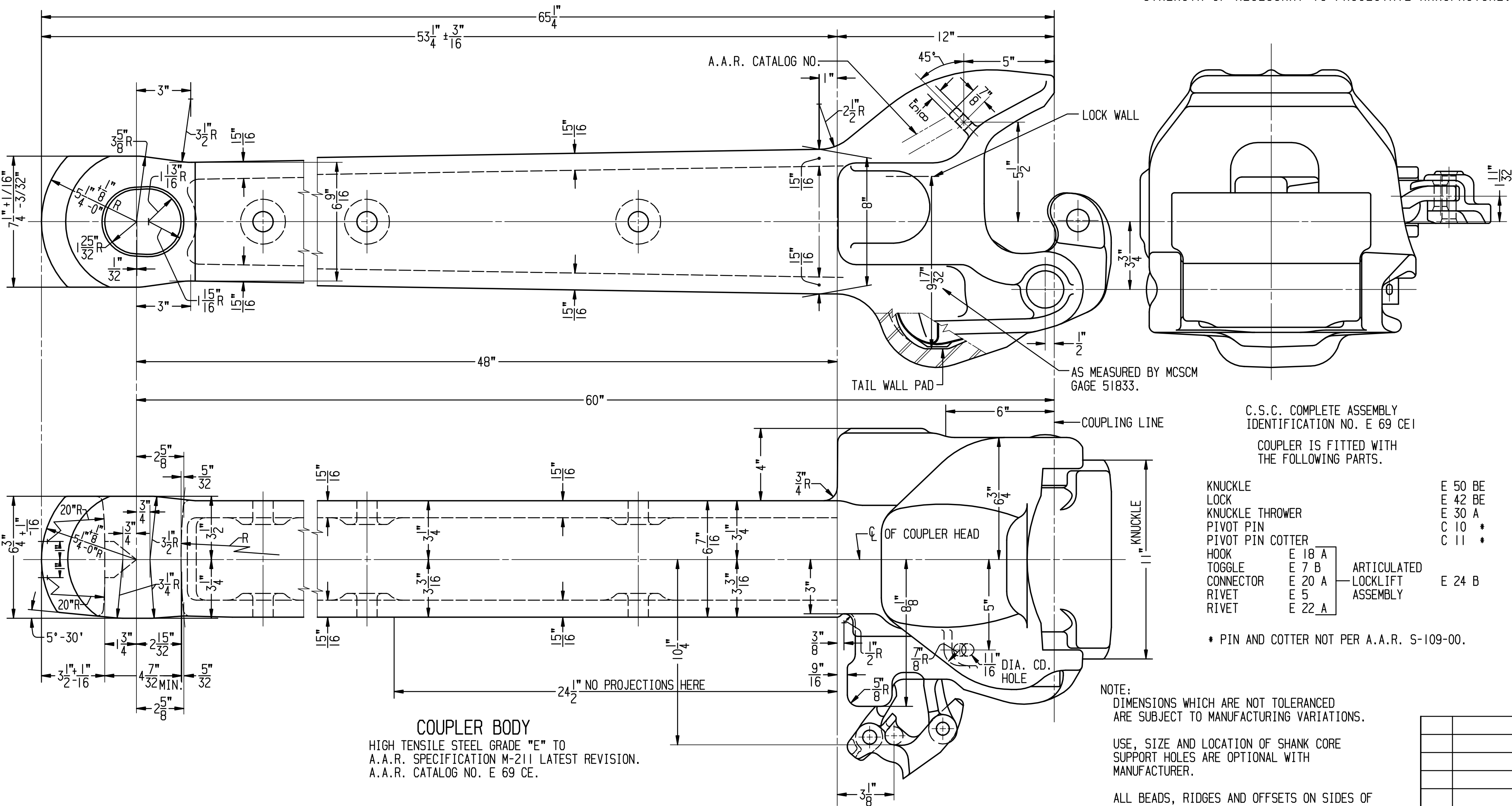

COUPLER BODY
 HIGH TENSILE STEEL GRADE "E" TO
 A.A.R. SPECIFICATION M-211 LATEST REVISION.
 A.A.R. CATALOG NO. E 69 CE.

- C.S.C. COMPLETE ASSEMBLY IDENTIFICATION NO. E 69 CE I
 COUPLER IS FITTED WITH THE FOLLOWING PARTS.
- | | | |
|------------------|---------|-------------------------------|
| KNUCKLE | E 50 BE | |
| LOCK | E 42 BE | |
| KNUCKLE THROWER | E 30 A | |
| PIVOT PIN | C 10 * | |
| PIVOT PIN COTTER | C 11 * | |
| HOOK | E 18 A | |
| TOGGLE | E 7 B | |
| CONNECTOR | E 20 A | ARTICULATED LOCKLIFT ASSEMBLY |
| RIVET | E 5 | |
| RIVET | E 22 A | |
| | | E 24 B |
- * PIN AND COTTER NOT PER A.A.R. S-109-00.

NOTE:
 DIMENSIONS WHICH ARE NOT TOLERANCED ARE SUBJECT TO MANUFACTURING VARIATIONS.
 USE, SIZE AND LOCATION OF SHANK CORE SUPPORT HOLES ARE OPTIONAL WITH MANUFACTURER.
 ALL BEADS, RIDGES AND OFFSETS ON SIDES OF COUPLER SHANK MUST BE REMOVED BY GRINDING.

C	3-22-2000
B	12-8-1999
A	4-13-1999
REV.	DATE

COUPLER AND PARTS ARE PATENTED.

TYPE E/F REDUCED SLACK COUPLER
 SINGLE ROTARY OPERATION
 CATALOG NO. E 69 CE

Columbus Steel Castings
 Columbus, Ohio

DRAWN BY M.H.G.	CHECKED BY K.A.C.	DATE 3-5-1997
C-14464		SCALE 3" = 1'-0"
		SHEET 1 OF 1

THIS DRAWING CONTAINS CONFIDENTIAL AND PROPRIETARY INFORMATION OF COLUMBUS STEEL CASTINGS ("COLUMBUS STEEL") AND THE DRAWING AND THE INFORMATION CONTAINED THEREIN ARE AND REMAIN THE PROPERTY OF COLUMBUS STEEL. THIS DRAWING IS PROVIDED WITH THE EXPRESS AGREEMENT THAT THE DRAWING AND THE INFORMATION THEREIN:
 (1) WILL NOT BE REPRODUCED, COPIED OR OTHERWISE TRANSCRIBED, IN WHOLE OR IN PART, BY ANY METHOD;
 (2) WILL NOT BE USED, IN WHOLE OR IN PART, DIRECTLY OR INDIRECTLY, TO ASSIST IN THE MAKING OR TO FURNISH ANY INFORMATION FOR THE MAKING, OF DRAWINGS, PRINTS, APPARATUS OR PARTS;
 (3) WILL NOT BE MADE AVAILABLE TO ANY OTHER PERSON OR ENTITY, IN EACH CASE WITHOUT THE PRIOR WRITTEN CONSENT OF COLUMBUS STEEL AS TO EACH SPECIFIC CASE; AND
 (4) WILL BE RETURNED TO COLUMBUS STEEL UPON ITS REQUEST.
 ACCEPTANCE OF THIS DRAWING SHALL CONSTITUTE ACCEPTANCE OF THE FOREGOING AGREEMENTS.